

BRANDINA  
PARKLIEGE  
SUN LOUNGE

ORIGINAL  
**euroform** W<sup>®</sup>

MOD. 340M

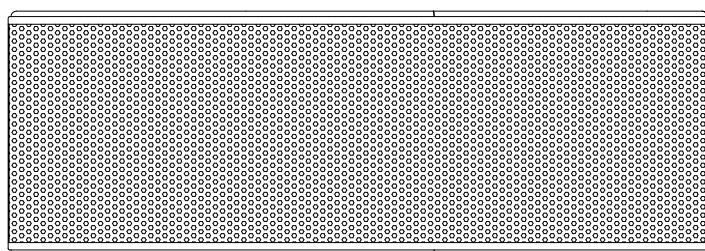
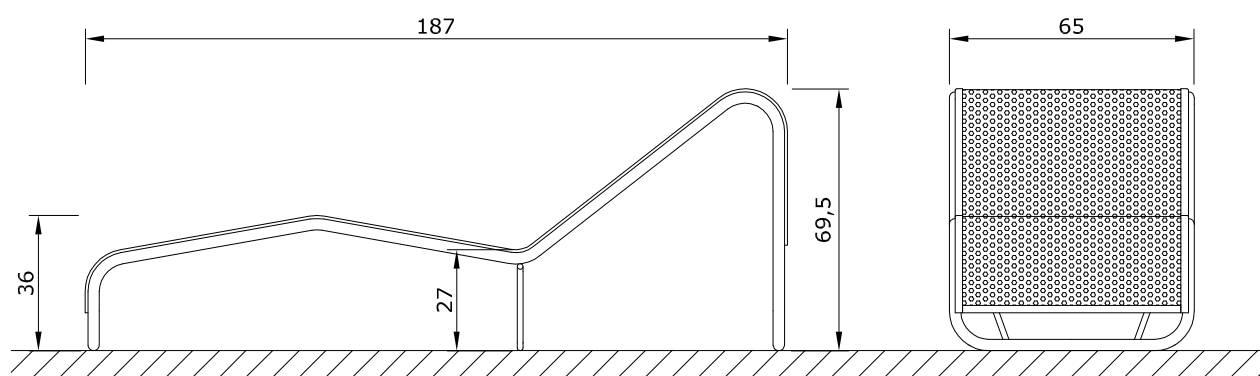

**Material frame:** tubular steel S235JRH, 30,0x3mm

**Material seat:** expanded metal DC04 thickness 3 mm knurled with a U-profile.

**Surface treatment:** hot dip galvanization according to UNI EN ISO 1461. Powder coating 80 micron, fine texture. Tested to 500 h salt spray test according to DIN 50021 or ISO 9227-SS. UV resistance of the powder to as detailed in the Qualicoat guarantee table.

**Designer:** Arch. Bernhard Winkler

Maßstab 1:20